

GS 04L05A01-00E

OVERVIEW

The DX100P is a DAQSTATION that can display measurement data on a color LCD screen in real-time, and store them to a compact flash memory card or Zip disk. It can be connected to Ethernet, Modbus, and other networks. A standard Ethernet port allows such network capabilities as sending messages by e-mail, remote monitoring through a Web browser, and file transfer with FTP, and time adjustment by SNTP.

The supported inputs include DC voltage, thermocouple, resistance temperature detector, and contact, each of which can be assigned to any channel. The DX100P is available in two-, four-, six-, and twelve-channel models.

With the accompanying software DAQSIGNIN, you can display measurement data saved on storage media, and then convert them into Lotus 1-2-3, Microsoft Excel, or ASCII format. You can also retrieve operation logs, apply the sign record functions to the data, and edit/save various configurations.



Input types: DCV (DC voltage), TC (thermocouple), RTD (resistance temperature detector), DI (digital input for event recording), DCA (DC current with external shunt resistor attached)

Measurement and measuring ranges:

STANDARD SPECIFICATIONS

General Specifications

Construction

Mounting: Flush panel mounting at an angle of up to 30 degrees in a backward direction with the left and right sides at the same level

Allowable panel thickness: 2 to 26 mm

Material: Case: Drawn steel

Bezel: Poly-carbonate

Front filter: Poly-carbonate

Color: Case: Grayish blue green (Munsell 2.0B5.0/1.7 or equivalent)

Bezel: Light charcoal gray (Munsell 10B3.6/0.3 or equivalent)

Front panel: Water and dust-proof (based on IEC529-IP65, NEMA No.250 TYPE 4 [except external icing test], except for side-by-side mounting)

Dimensions: 144 (W) × 144 (H) × 218 (D) mm

Weight: DX102P: Approx. 2.9 kg

DX104P: Approx. 3.0 kg

DX106P: Approx. 3.0 kg

DX112P: Approx. 3.0 kg

Input

Number of inputs: DX102P: 2

DX104P: 4

DX106P: 6

DX112P: 12

Measurement intervals:

DX102P, DX104P: 125 ms

DX106P, DX112P:

1 s (2 s when an A/D integration time is set to 100 ms.)

Input type	Range	Measuring range	
DCV	20 mV	-20.00 to 20.00 mV	
	60 mV	-60.00 to 60.00 mV	
	200 mV	-200.0 to 200.0 mV	
	2 V	-2.000 to 2.000 V	
	6 V	-6.000 to 6.000 V	
	20 V	-20.00 to 20.00 V	
TC	R ^{*1}	0.0 to 1760°C	32 to 3200°F
	S ^{*1}	0.0 to 1760°C	32 to 3200°F
	B ^{*1}	0.0 to 1820°C	32 to 3200°F
	K ^{*1}	-200.0 to 1370°C	-328 to 2498°F
	E ^{*1}	-200.0 to 800°C	-328.0 to 1472.0°F
	J ^{*1}	-200.0 to 1100°C	-328.0 to 2012.0°F
	T ^{*1}	-200.0 to 400°C	-328.0 to 752.0°F
	N ^{*1}	0.0 to 1300°C	32 to 2372°F
	W ^{*2}	0.0 to 2315°C	-328.0 to 4199°F
	L ^{*3}	-200.0 to 900°C	-328.0 to 1652.0°F
	U ^{*3}	-200.0 to 400°C	-328.0 to 752.0°F
RTD ^{*5}	Pt100 ^{*4}	-200.0 to 600°C	-328.0 to 1112.0°F
	JPt100 ^{*4}	-200.0 to 550°C	-328.0 to 1022.0°F
DI	DCV input (TTL)	OFF : less than 2.4 V	
		ON : more than 2.4 V	
	Contact input	Contact on/off	

*1 R, S, B, K, E, J, T, N : IEC584-1 (1995), DIN IEC584, JIS C1602-1995

*2 W : W-5% Rd/W-26% Rd (Hoskins Mfg. Co.), ASTM E988

*3 L : Fe-CuNi, DIN43710, U : Cu-CuNi, DIN43710

*4 Pt100 : JIS C1604-1997, IEC751-1995, DIN IEC751-1996
JPt100 : JIS C1604-1989, JIS C1606-1989

*5 Measuring current : i = 1 mA

A/D integration time:
20 ms (50 Hz), 16.7 ms (60 Hz), 100 ms (50/60 Hz, DX106P and DX112P only), or Auto (switching 20 ms and 16.7 ms by power supply frequency).

Thermocouple burnout:
Detector on/off selection for each channel
Burnout upscale/downscale selectable

Filter:
DX102P, DX104P:
Filter on/off selectable for each channel
Time constant: selectable from 2, 5, or 10 sec..
DX106P, DX112P:
Moving average on/off selectable for each channel with averaging number selected from 2 to 16.

Calculations:
Differential computation:
The difference between any two channels.
Applicable inputs: DCV, TC, RTD

Linear scaling:
Applicable inputs: DCV, TC, RTD
Scaling limits: -30,000 to 30,000
Decimal point: user-selectable.
Engineering unit: user-definable, up to 6 characters.

Square-root:
Applicable inputs: DCV
Scaling limits: -30,000 to 30,000
Decimal point: user-selectable.
Engineering unit: user-definable, up to 6 characters.

● Display

Display unit: 5.5-inch TFT color LCD (QVGA320 × 240 pixels)

Note: Some of the LCD pixels may be normally lit or never be lit. Or brightness may not be uniform due to the LCD characteristics. Neither of these indicate that the LCD is defective.

Display colors:
Trend and bar graph displays: Selectable from 12 colors
Background: Black or white

Trend display:
Direction: Vertical or horizontal selectable
Number of channels: Max. 6 per display (1 group)
All channels display: Max. 12 channels
Number of displays: 6 (6 groups)
Line width: 1, 2, or 3 pixels selectable
Waveform span rate:
DX102P, DX104P:
15 or 30 sec.; 1, 2, 5, 10, 15, 20, or 30 min.; or 1, 2, 4, or 10 hours/div selectable

DX106P, DX112P:
1, 2, 5, 10, 15, 20, or 30 min.; or 1, 2, 4, or 10 hours/div selectable

Bar graph display:
Direction: Vertical or horizontal selectable
Number of channels: Max. 6 per display (1 group)
Number of displays: 6 (6 groups)
Scale: 4 to 12
Referential position: Left, right or center
Updating rate: 1 s

Digital display:
Number of channels: Max. 6 per display (1 group)
Number of displays: 6 (6 groups)

Updating rate: 1 s
Overview display:
Number of channels:
Measured values and alarms statuses on all channels
Information display:
Selecting an area with the cursor jumps to the corresponding trend display.
Alarm summary display: Lists alarm summary.
Alarm ACK summary display: Lists alarm ACK summary.
Message summary display:
Lists messages and the times.
Memory information:
Lists files stored in internal memory.

Tags:
Number of characters: Max. 16
Characters: Alphanumeric

Other displayed data:
Memory status, scale values (0, 100%, display on/off selectable), max. 6 scales, grids lines (4 to 12 divisions or auto) and hour:minute, time (year/month/day, hour:minute:second), trip levels (1, 2, or 3 pixels wide), messages (max. 32 characters and 64 types), alarm indication

Data reference:
Data from internal memory or external storage media (display data and event data) can be retrieved.

Display format: Whole display

Time axis operation:
Display reducing, enlarging, and scrolling

Auto display scroll:
Auto-scrolling of displayed groups at preset intervals (5, 10, 20, or 30 s.; or 1 min.) on monitor display

LCD saving: Turns off the LCD backlight when there is no key operation for a specified period (1, 2, 5, 10, 20, or 60 min.).

● Data saving functions

External storage media:
Selectable from:
• Zip disk
• Compact flash memory card
(with PC card adapter)

Data saving method: Automatic
Display data: Saves data to external storage media at periodic intervals (10 min. to 31 days) or upon key operation.

Event data: Saves data to external storage media at periodic intervals (3 min. to 31 days) or upon key operation.

Media FIFO function : Allows the oldest file to be deleted and the newest file to be saved if the free space on the external storage media is insufficient (on / off selectable).

Data saving period:
Display data files: Linked to waveform span rate.

Event files: The sampling period is specified.

Event file sampling period:
DX102P, DX104P:
125, 250, or 500 ms; or 1, 2, 5, 10, 30, 60, 120, 300, or 600 s

DX106P, DX112P:
1, 2, 5, 10, 30, 60, 120, 300, or 600 s

Measurement data files:

The following two file types can be selected:

- (1) Event data file: Saves instantaneous values sampled at a specified sampling period.
- (2) Display data file: Saves maximum and minimum values within the waveform span rate from measurement data sampled at a specified measurement interval.

Data format: Binary

Data per channel:

Display data:

Measurement data:

4 bytes/data

Mathematical data: 8 bytes/data

Event data:

Measurement data:

2 bytes/data

Mathematical data: 4 bytes/data

Sampling time:

Display data file only:

When the number of measurement channels and computing channels are 12 and 6 respectively, and display updating interval is 30 minutes/div (data saving interval is 60 sec.):

Number of data records per file =
 $5,000,000 \text{ bytes} / (12 \times 4 \text{ bytes} + 6 \times 8 \text{ bytes} + 8 \text{ bytes}) = 48,076$
 Sampling time per file = $48,076 \times 60 \text{ sec.} = 2,884,560 \text{ sec.} = \text{Approx. } 33 \text{ days}$

Event data file only:

When the number of measurement channels and computing channels are 12 and 6 respectively, the data saving interval is 1 sec.:

Number of data records per file =
 $5,000,000 \text{ bytes} / (12 \times 2 \text{ bytes} + 6 \times 4 \text{ bytes} + 8 \text{ bytes}) = 89,285$
 Sampling time per file = $89,285 \times 1 \text{ sec.} = 89,285 \text{ sec.} = \text{Approx. } 24 \text{ hours}$

Examples of sampling time:

In case measurement ch = 4ch, mathematical ch = 0 ch:

Only display data file

Waveform span rate (min/div)	1	5	20	30	60	240
Data saving period (s)	2	10	40	60	120	480
Sampling time (Approx.)	115 hrs	24 days	96 days	114 days	289 days	1157 days

Only event data file

Data saving period	125 ms	500 ms	1 sec	5 sec	30 sec	120 sec
Sampling time (Approx.)	7.2 hrs	28 hrs	57 hrs	12 days	72 days	289 days

In case measurement ch = 6, mathematical ch = 0:

Only display data file

Waveform span rate (min/div)	1	5	20	30	60	240
Data saving period (s)	2	10	40	60	120	480
Sampling time (Approx.)	86 hrs	18 days	72 days	108 days	217 days	868 days

Only event data file

Data saving period (s)	1	5	10	30	60	120
Sampling time (Approx.)	69 hrs	14 days	28 days	86 days	173 days	347 days

Manual sample data:

Trigger: Key operation or remote contact

Data format: ASCII

Max. number of stored data 50

TLOG data (only for MATH option):

Trigger: Time up of TLOG interval

Report data (only for MATH option):

Types: Hourly, daily, hourly + daily, daily + weekly, daily + monthly

Data format: ASCII

Snapshot:

Trigger: Key operation

Data format: PNG format

Output: External storage media or communication interface

● System access functions

When the power is turned on, the DX100P starts up in a secure mode, prohibiting any unauthorized access (only the monitor display can be switched (on / off selectable)). You can log in to the DX100P by entering your user name, user ID, and password.

System administrator:

Up to 3 users can be registered. They can access all keys.

User:

Up to 90 users can be registered. Key restrictions and electronic signature settings can be assigned for each user.

Log in mode setting: 30 patterns

Password expiration: Off, 1, 3, or 6 months

Auto Logout: Off, 1, 2, 5, or 10 minutes.

● Batch functions

When in operation mode, batch names (batch number of up to 32 characters + lot number of 8 digits) and comments (up to 32 characters × 3 lines) can be specified. The lot number can be automatically incremented every time the batch function starts. In the batch number enter display, preset headers 1, 2, and 3 (up to 64 characters each) can be referred to.

Display, event data files:

The following information is added to the attached information of data files:

- User name
- Header 1: Can be used for specifying application names or the like.
- Header 2: Can be used for specifying supervisor names or the like.

- Header 3: Can be used for specifying manager names or the like.
- Batch name: (batch number of up to 32 characters + lot number of 8 digits)
- Comment (up to 32 characters × 3 lines)

● **Electronic signature functions**

Up to 3 signature positions can be applied to a record; each requires log in with user name, user ID, and password. Data review with pass/fail choice, and comment field of up to 32 characters is provided at the time a signature is applied.

● **Alarm functions**

Number of alarms: Max. 4 for each channel
 Alarm types: High/low limit, differential high/low limit, high/low rate-of-change limit, delay high/low limit (alarm delay)
 Interval time of rate-of-change alarms: Measurement interval times 1 to 15
 Alarm delays: 1 to 3600 s
 Displays: When an alarm occurs, the status (alarm type) is displayed on the digital display. A common alarm indication is also displayed. The alarming behavior: non-hold or hold-type can be selectable for common to all channels.
 Hysteresis: On (0.5% of span) or Off (Common to all channels/levels)
 Outputs: Number of outputs: 2, 4, or 6 (optional) Energized/deenergized and hold/non-hold selectable
 Memory:
 Stored information: Alarm on/off times, alarm types
 Number of stored records: Max. 240 of most recent
 ACK: Can be activated for each alarm or all alarms.

● **Communication functions**

Connection: Ethernet (10BASE-T)
 Protocols: SMTP, HTTP 1.0, FTP, TCP, UDP, IP, ARP, ICMP, SNTP
 E-mail transfer:
 Destination address:
 2 address groups (Two or more addresses containing up to 150 characters in total can be specified for each group.)
 Message types:
 The following information can be sent by e-mail. You can select whether or not to notify each address group with this information.
 Alarm message:
 E-mail of alarm status upon occurrence of and recovery from an alarm.
 System message:
 E-mail upon occurrence of and system recovery from a power failure. Notifies of remaining time before starting overwrite of internal memory. Notifies that remaining space of storage media is reduced to 10% or 6 MB.
 Scheduled time message:
 Periodic notification of instantaneous values at a specified time or specified intervals.

Report message:
 Notifies of report data upon report timeout (only available with /M1 option).

User invalid :
 Notifies of user becoming invalid because of entering the wrong password three times.

Web server functions:
 You can view the display image, alarm information, instantaneous values, and other information from the DX100P main unit, using Microsoft Internet Explorer 5.0.

FTP client functions:
 Automatic file transfer from the DX100P (display data files, event data files, report data files and snap shot file)

FTP server functions:
 Manual transfer of files in external storage media, directory operations, and obtaining of information on remaining free storage space of external storage media, from host computer

Monitoring functions:
 Real time monitoring DX100P data by communication (YOKOGAWA private protocol)

Setting functions:
 DX100P configuration via communication (YOKOGAWA private protocol)

SNTP client functions :
 The time on the DX100P can be synchronized to the time of a SNTP server.

SNTP server functions :
 The DX100P can operate as a SNTP server.

● **Power supply**

Rated power supply:
 100 to 240 V AC (automatic switching)
 Allowable power supply voltage ranges:
 90 to 132, 180 to 250 V AC
 Rated power supply frequencies:
 50/60 Hz (automatic switching)
 Power consumption:

Supply Voltage	LCD Saving Mode	Normal	Maximum
100 V AC	Approx. 30 VA	Approx. 32 VA	Approx. 45 VA
240 V AC	Approx. 42 VA	Approx. 47 VA	Approx. 62 VA

● **Other specifications**

Clock with calendar function:
 Adjustable with external contact (only available with remote option)
 Summer/winter time:
 Summer and winter time can be set.
 Clock accuracy:
 ±100 ppm except for delay (1 s or less) when the power is turned on.
 Memory backup:
 Backs up settings with built-in lithium battery (service life: approx. 10 years at room temperature).
 Insulation resistance:
 20 MΩ or greater between each terminal and ground for a supply of 500 V DC

Dielectric strength:

- Between power supply terminal and ground terminal:
1500 V AC (50/60 Hz) for 1 min.
- Between contact output terminals and ground terminal:
1500 V AC (50/60 Hz) for 1 min.
- Between input terminals and ground terminal:
1500 V AC (50/60 Hz) for 1 min.
- Between input terminals:
1000 V AC (50/60 Hz) for 1 min. (except for the b terminal of RTD inputs of the DX106P and DX112P.)
- Between remote control terminal and ground:
500 V DC for 1 min.

● Safety and EMC standards

CSA: CSA22.2 No1010.1 installation category II*1, pollution degree 2*2

UL: UL61010B-1 (CSA NRTL/C)

CE:

EMC directive:

- EN61326 compliance (Emission: Class A, Immunity: Annex A)
- EN61000-3-2 compliant
- EN61000-3-3 compliant
- EN55011 compliant, Class A Group 1

Low voltage directive:

- EN61010-1 compliant, measurement category II*3, pollution degree 2*2

C-Tick: AS/NZS 2064 compliant, Class A Group 1

*1: Installation Category (Overvoltage Category) II

Describes a number which defines a transient overvoltage condition. It implies the regulation for impulse withstand voltage. "II" applies to electrical equipment which is supplied from fixed installations like distribution boards.

*2: Pollution Degree

Describes the degree to which a solid, liquid, or gas which deteriorates dielectric strength or surface resistivity is adhering. "2" applies to normal indoor atmosphere. Normally, only non-conductive pollution occurs.

*3: Measurement Category II

Applies to measuring circuits connected to low voltage installation, and electrical instruments supplied with power from fixed equipment such as electric switchboards.

External noise:

Normal mode (50/60 Hz):

DC voltage: Peak value including signals of measurement range times 1.2 or less

TC: Peak value including signals of thermal electromotive force times 1.2 or less

RTD: 50 mV or less

Common mode noise voltage (50/60 Hz):

250 Vrms AC or less for all ranges

Max. noise voltage between channels (50/60 Hz):

250 Vrms AC or less for all ranges

Mounting position:

A tilt of up to 30 degrees in a backward direction with the left and right sides at the same level

Warm-up time:

At least 30 min. after power on

■ NORMAL OPERATING CONDITIONS**Power voltage:**

90 to 132, 180 to 250 V AC

Power supply frequency:

50 Hz $\pm 2\%$, 60 Hz $\pm 2\%$

Ambient temperature:

0 to 50°C (5 to 40°C when using Zip drive)

Ambient humidity:

20 to 80% RH (at 5 to 40°C)

Vibration: 10 to 60 Hz, 0.2 m/s² or less

Shock: No shock is allowable.

Magnetic field: 400 A/m or lower (DC, 50 and 60 Hz)

STANDARD PERFORMANCE

Measurement and display accuracy:

(Reference operating conditions: temperature of $23 \pm 2^\circ\text{C}$, humidity of $55 \pm 10\%$ RH, supply voltage of 90 to 132 or 180 to 250 V AC, supply frequency of $50/60 \text{ Hz} \pm 1\%$, minimum 30-minute warm-up time; no vibrations or other factors which would adversely affect the performance of measuring instruments)

Input	Range	Measurement accuracy (digital display)	Max. resolution of digital display
DC voltage	20mV	$\pm(0.1\%$ of rdg 2digits)	10 μV
	60mV		10 μV
	200mV		100 μV
	2V		1mV
	6V		1mV
	20V		10mV
	50V	$\pm(0.1\%$ of rdg 3digits)	10mV
TC (without reference) unction compensation accuracy	R	$\pm(0.15\%$ of rdg + 1°C)	0.1 $^\circ\text{C}$
	S	However,	
	B	R, S : $\pm 3.7^\circ\text{C}$ at 0 to 300°C , $\pm 1.5^\circ\text{C}$ at 100 to 300°C B : $\pm 2^\circ\text{C}$ at 400 to 600°C (Accuracy at less than 400°C is not guaranteed.)	
	K	$\pm(0.15\%$ of rdg 0.7 $^\circ\text{C}$) However, $\pm(0.15\%$ of rdg + 1°C) at -200 to -100 $^\circ\text{C}$	
	E	$\pm(0.15\%$ of rdg + 0.5 $^\circ\text{C}$)	
	J	$\pm(0.15\%$ of rdg + 0.5 $^\circ\text{C}$)	
	T	However, $\pm(0.15\%$ of rdg + 0.7 $^\circ\text{C}$) at -200 to -100 $^\circ\text{C}$	
	N	$\pm(0.15\%$ of rdg + 0.7 $^\circ\text{C}$)	
	W	$\pm(0.15\%$ of rdg + 1°C)	
	L	$\pm(0.15\%$ of rdg + 0.5 $^\circ\text{C}$)	
U	However, $\pm(0.15\%$ of rdg + 0.7 $^\circ\text{C}$) at -200 to -100 $^\circ\text{C}$		
RTD	Pt100	$\pm(0.15\%$ of rdg + 0.3 $^\circ\text{C}$)	
	JPt100		

Measurement accuracy when using scaling function:

$$\frac{\text{Measurement accuracy with scaling (digits)} = \text{measurement accuracy (digits)}}{\text{Scaling span (digits)}} + 2 \text{ digits}$$

*: Rounded up to nearest whole number

Reference junction compensation:

INT (internal)/EXT (external) selectable
(common to all channels)

Reference junction compensation accuracy:

Types R, S, B, W: $\pm 1^\circ\text{C}$

Types K, J, E, T, N, L, U:

$\pm 0.5^\circ\text{C}$ (for measurement at 0°C or higher)

Maximum input voltage:

2 V DC or lower voltage and thermocouple:

$\pm 10 \text{ V DC}$ (continuous)

6 V DC or higher voltage:

$\pm 60 \text{ V DC}$ (continuous)

Input resistance:

2 V DC or lower voltage and thermocouple:

10 M Ω or greater

6 V DC or higher voltage: Approx. 1 M Ω

Input source resistance:

DC voltage, thermocouple input: 2 k Ω or less

RTD input: 10 Ω or less for one line (all three lines must be equal)

Input bias current: 10 nA or less

Max. common mode noise voltage:

250 Vrms AC (50/60 Hz)

Max. noise voltage between channels:

250 Vrms AC (50/60 Hz)

Interference between channels:

120 dB (input external resistance: 500 Ω ,
input to other channels: 30 V)

Common mode rejection ratio:

120 dB (50/60 Hz $\pm 0.1\%$, 500 Ω unbalanced, between negative terminal and ground)

Normal mode rejection ratio:

40 dB (50/60 Hz $\pm 0.1\%$)

EFFECTS ON OPERATING CONDITIONS

Ambient temperature:

Fluctuation caused by 10°C change:

$\pm(0.1\%$ of rdg + 1 digit) or less

*Excluding error in reference junction compensation

$\pm(0.1\%$ of rdg + 2 digits) or less for RTD inputs

Voltage fluctuation:

90 to 132 or 180 to 250 V AC (50/60 Hz): ± 1 digit or less

Rated supply frequency $\pm 2 \text{ Hz}$ (supply voltage:

100 V AC): $\pm(0.1\%$ of rdg + 1 digit) or less

Magnetic field:

Fluctuations in AC voltage (50/60 Hz) and DC 400 A/

m: 100 V AC): $\pm(0.1\%$ of rdg + 10 digits) or less

Input source resistance:

Fluctuations caused by signal source resistance
+ 1 k Ω

(1) DC voltage ranges

2 V DC range or less: within $\pm 10 \mu\text{V}$

6 V DC range or greater: -0.1% of rdg or less

- (2) Thermocouple ranges within $\pm 10 \mu\text{V}$ ($\pm 100 \mu\text{V}$ when burnout is on)
- (3) RTD ranges (Pt100)
 - (I) Fluctuation for 10Ω change per line (all three lines must have an identical resistance.): $\pm(0.1\%$ of rdg + 1 digit) or less
 - (II) Fluctuation for $40\text{m}\Omega$ change in inter-line resistance difference (max. difference between three lines): Approx. 0.1°C

TRANSPORTATION AND STORAGE CONDITIONS

The following environment conditions apply to transportation and storage of the product from shipment to start of operation and those for temporary nonoperation. Under these conditions, the product can be returned to normal operation without unreparable damage even though it may need re-adjustment work.

- Ambient temperature: -25°C to 60°C
- Humidity: 5 to 95% RH (no condensation)
- Vibration: 10 to 60 Hz, 4.9 m/s^2 or lower
- Shock: 392 m/s^2 or lower (when packed)

SPECIFICATIONS FOR OPTIONAL FUNCTIONS

Easy Text Entry(/KB1, /KB2)

Remote Control Specifications

- Normal operating conditions:
 - Ambient temperature for usage: 0 to 40°C
 - Ambient temperature for storage: -10 to 60°C
 - Ambient humidity for storage: 5 to 95% RH (When to 40°C , no condensation)

- Power supply: AA dry battery $\times 2$
- Weight: Approx. 60 g (excluding dry battery)
- Dimensions: $170 \text{ (W)} \times 50 \text{ (H)} \times 23.7 \text{ (D)} \text{ mm}$

Combination specifications with DX100P/DX200P

- Number of units that can be controlled: Max. 32 units by ID setting
- Communication distance: Max. 8 m (depending on battery strength and usage area).
- Orientation specifications: Depends on battery strength & usage area

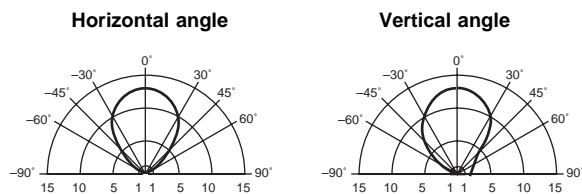

Communication distance

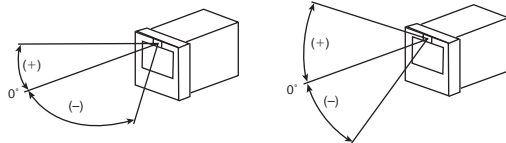

Calibration correction (/CC1)

- Functions: Input value correction with linearization
- Points: Selectable from off, 2 to 16
- Target Channel: Measurement channel
- Target range: All range mode

Alarm Output Relays (/AR1, /AR2, /A3)

- Relay output performed from the rear when an alarm occurs.
- /AR1 and /AR2 includes remote control functions (/R1)
- Number of outputs: 2, 4, or 6
- Relay contact rating: 250 V DC/0.1 A (resistance load), 250 V AC (50/60 Hz)/3 A
- Terminal configuration: SPDT (NO-C-NC). Energized-at- alarm/ deenergized-at-alarm, AND/OR, and hold/ non-hold actions are selectable.

Serial Communication Interface (/C2, /C3)

- Allows the host computer to control (available control commands are limited) the DX100P as well as receive data from the DX100P.
- Connection: EIA RS-232 (/C2) or RS-422-A/485 (4 wire) (/C3)
- Protocol: YOKOGAWA private protocol, Modbus protocol
- Synchronization: Start-stop asynchronous transmission
- Connection type (RS-422-A/485): 4-wire half-duplex multi-drop connection (1:N where N is 1 to 31)
- Transmission speed: 1200, 2400, 4800, 9600, 19200, 38400 bps
- Data length: 7 or 8 bits
- Stop bit: 1 bit
- Parity: Odd, even, or none
- Max. line length (RS-422-A/485): 1.2 km
- Communication modes:
 - ASCII or binary for measurement data output
 - ASCII for input / output for control
- Modbus communication:
 - Operation mode: RTU MASTER or RTU SLAVE
 - RTU MASTER:
 - Can acquire 8 packet groups' data.
 - Consecutive registers of the same data type within an identical slave can be grouped into a one packet group.
 - RTU SLAVE:
 - Outputs measurement and calculation data and alarm statuses.
- Barcode protocol:

User name and UserID for logging in, free message, batch information and batch Comment entry

● **FAIL/Memory End Output (/F1)**

Two relay outputs are selectable from FAIL/memory end and batch start/stop.

FAIL/memory end output

FAIL: When a system error occurs.

Memory end: Prior to the specified start time for internal memory overwriting (1, 2, 5, 10, 20, 50, or 100 hours), or when remaining space of storage media is reduced to 10% or 6 MB.

Batch start/stop: Outputs batch start/stop status.

User invalid:

When a user becomes invalid because of entering the wrong password three times.

Login status:

When the login function is enabled and there is a user logged in the DX100P.

Relay contact rating:

250 V DC/0.1 A (resistance load), 250 V AC (50/60 Hz)/3 A

● **Clamped Input Terminal (/H2)**

A clamp input terminal is used as an input terminal.

● **Desk Top Type (/H5[], /H5)**

Includes handle for carrying product and power cord.

Note: Always specify /H5 when /P1 is also specified. In this case, the power supply terminal is a screw type and thus the power cord is omitted.

● **Mathematical Functions (/M1)**

The following calculations are available in addition to displaying and recording trends and digital values on calculation channels.

Number of calculation channels:

DX102P, DX104P: 8

DX106P, DX112P: 12

Operation:

General arithmetic operations:

Four arithmetic operations, square roots, absolute, common logarithms, exponential, power, relational operations (<, ≤, >, ≥, =, ≠), logic operations (AND, OR, NOT, XOR)

Statistical operations:

Average, maximum, minimum and summation

Constants: Up to 12 constants can be set.

Digital data input via communication:

Up to 12 records can be input through online digital communications. They can be used with mathematical expression.

Remote status input:

Up to 8 remote inputs can be used. Remote statuses (0/1) can be used in mathematical expression.

Report functions:

Report types:

Hourly, daily, hourly + daily, daily + weekly, daily + monthly

Operation: Average, maximum, minimum, summation

Data format: ASCII

● **Cu10/Cu25 RTD input/3 legs isolated RTD input (/N1)**

This option enables Cu10 and Cu25 inputs in addition to the standard inputs. With DX106P and DX112P, all input points of A, B, and b are isolated.

	Input Type	Measuring Range
RTD (Measuring current i = 1.25 mA)	Cu10 (GE)	-200°C to 300°C
	Cu10 (L&N)	
	Cu10 (WEED)	
	Cu10 (BAILEY)	
	Cu10 α 0.00392 at 20°C	
	Cu10 α 0.00393 at 20°C	
	Cu25 α 0.00425 at 0°C	

Input Type	Accuracy Guarantee Range	Measurement Accuracy
Cu10 (GE)	-70°C to 170°C	±(0.4% of rdg + 1.0°C)
Cu10 (L&N)	-75°C to 150°C	
Cu10 (WEED)	-200°C to 260°C	
Cu10 (BAILEY)	-200°C to 300°C	
Cu10: α = 0.00392 at 20°C		
Cu10: α = 0.00393 at 20°C		
Cu25: α = 0.00425 at 0°C		±(0.3% of rdg + 0.8°C)

Note: With the /N1 option, the accuracy of Pt100/JPt100 input is ±(0.3% of rdg + 0.6°C).

● **3 legs isolated RTD input (/N2)**

With this option, all RTD input points (A, B, and b) are isolated.

Note: Only available with the DX106P and DX112P. The DX102P and DX104P come standard with A, B, and b isolated.

● **24 V DC/AC power supply (/P1)**

Rated power supply: 24 V DC/AC

Operating power supply voltage range:

21.6 to 26.4 V DC/AC

Dielectric strength:

500 V AC between power supply terminal and ground

Power consumption:

Supply Voltage	LCD Saving Mode	Normal	Maximum
24 V DC	Approx. 17 VA	Approx. 19 VA	Approx. 30 VA
24 V AC (50/60 Hz)	Approx. 28 VA	Approx. 32 VA	Approx. 45 VA

● **Remote control (/R1)**

The following can be controlled through contact input (up to 8 points can be set):

- Memory start/stop (level)
- Time adjustment (time set to reference time; trigger; 250 ms or longer)

Time of Trigger-on	Processing
00'00" to 01'59"	Rounds down to the hour. e.g. 10:00:50 → 10:00:00
58'00" to 59'59"	Rounds up to the hour. e.g. 10:59:50 → 11:00:00
02'00" to 57'59"	None

- Computation start/stop (level)
- Computation data reset (trigger; 250 ms or longer)

- Manual data sample (trigger; 250 ms or longer)
- Message display (up to 8 messages can be set; trigger; 250 ms or longer)
- Alarm ACK (trigger; 250 ms or longer)
- Snapshot (trigger; 250 ms or longer)

● **24 V DC transmitter power supply (/TPS2, /TPS4)**

Output voltage:
22.8 to 25.2 V DC (rated load current)

Rated output current:
4 to 20 mA DC

Max. output current:
25 mA DC (overcurrent protection: Up to approx. 68 mA DC)

Allowable conductor resistance:
 $RL \leq (17.8 - \text{transmitter's min. operating voltage})/0.02 \text{ A}$
 (at load shunt resistance of 250 Ω, excluding voltage drop)

Max. length of wiring:
2 km (when CEV cable used)

Insulation resistance:
20 MΩ or greater for 500 V DC between output terminals and DX100P ground

Dielectric strength:
500 V AC (50/60 Hz, I = 10 mA) for 1 min. between output terminals and between output terminals and DX100P ground

■ **APPLICATION SOFTWARE**

● **DAQSIGNIN**

System requirements

Operating system:
Microsoft Windows 98 (Internet Explorer 3.02 or later)/Me/NT 4.0 (service pack 3 or later)/2000/XP

CPU: Pentium II 233 MHz or faster

Memory: At least 64 MB

Disk device:
CD-ROM drive compatible with Windows 98/Me/NT4.0/2000/XP

Hard disk: At least 20 MB of free space

Display card:
Compatible with Windows 98/Me/NT 4.0/2000/XP and capable of displaying 64,000 colors or more

Printer: Printer and printer driver compatible with Windows 98/Me/NT 4.0/2000/XP

Communication interface:
Ethernet board compatible with Windows (TCP/IP needs to be installed with OS.)

Main functions (package)

- Data manager
Displays data lists in batches or data types.
- Data viewer
Retrieves batch data, displays sign-in and operation history, prints retrieved data, and converts file to ASCII, Lotus 1-2-3, or MS Excel format.
- Configuration
DX100P settings using Ethernet or external storage media.

■ **MODEL AND SUFFIX CODES**

Model	Suffix Code	Option Code	Description
DX102P			DAQSTATION DX100P (2ch)
DX104P			DAQSTATION DX100P (4ch)
DX106P			DAQSTATION DX100P (6ch)
DX112P			DAQSTATION DX100P (12ch)
External Memory	-3		Compact flash memory card (with medium)
	-5		250 MB Zip (with medium)
Display Language		-2	English, deg F & Summer/winter time(with English DAQSIGNIN)
Option Specifications		/AR1	Alarm output 2 points/Remote control *1 *2
		/AR2	Alarm output 4 points/Remote control *1 *2
		/A3	Alarm output 6 points *1 *3
		/C2	RS-232 interface (including Modbus) *4 *5
		/C3	RS-422-A/485 interface (including Modbus) *4 *5
		/F1	FAIL/memory end output *3
		/H2	Clamped input terminal
		/H5	Desktop type (without power cord, screw type power terminal) *6
		/H5[]	Desktop type (with power cord) *7
		/M1	Mathematical function (with report function)
		/N1	Cu10, Cu25 RTD input/3 legs isolated RTD
		/N2	3 legs isolated RTD *8
		/P1	24 VDC/AC power supply
	/R1	Remote control	
	/TPS2	24 V DC Power Supply for Transmitter (2 loop) *9	
	/TPS4	24 V DC Power Supply for Transmitter (4 loop) *10	
	/KB1	Easy Text Entry (with wireless hand held remote) *11 *12	
	/KB2	Easy Text Entry (without wireless hand held remote) *11	
	/CC1	Calibration Correction	

- *1 /AR1, /AR2 and /A3 cannot be specified together.
- *2 If /AR1 or /AR2 is specified, /R1 cannot be specified.
- *3 If /A3 is specified, /F1 cannot be specified.
- *4 /C2 and /C3 cannot be specified together.
- *5 When Modbus master function is utilized, /M1 must be specified.
- *6 When 24 VDC/AC power supply (/P1) and desktop type are specified together, /H5 must be specified. /P1 and /H5[] cannot be specified together.
- *7 /H5[](D-Power cord UL, CSA st'd, F-Power cord VDE st'd, R-Power cord SAA St'd, J-Power cord BS st'd)
- *8 /N2 cannot be specified for DX102P and DX104P.
- *9 When /TPS2 is specified, /TPS4, /AR2, /A3 or /F1 cannot be specified.
- *10 When /TPS4 is specified, /TPS2, /AR1, /AR2, /A3 or /F1 cannot be specified.
- *11 /KB1 and /KB2 cannot be specified together.
- *12 When /KB1 is specified, input terminal (438227) is included.

Application Software

Model	Description	Operating System
DXA150-02	DAQSIGNIN	Windows 98/Me/NT 4.0/2000/XP

STANDARD ACCESSORIES

Item (s)	Quantity
Mounting brackets	2
Fuse	1
Terminal screw	5
Instruction manual	1
Zip disk (250 MB)	1*1
Compact flash memory card (32 MB or more) + PC card adapter	1*2

*1: Only for DX1[] []P - 5 model.

*2: Only for DX1[] []P - 3 model.



Input terminal (4382 27)

/KB1 Specified

Item (s)	Quantity
AA alkali dry battery	2
Seal for input terminal	2

OPTIONAL ACCESSORIES

Product	Model (Part number)	Specifications
IQ/OQ Validation Protocol Documents	438221	Electronic file for DX100P
	438222	A4 sized paper for DX100P
	438323	Letter sized paper for DX100P
Shunt resistor for screw terminal	415920	250 Ω ± 0.1%
	415921	100 Ω ± 0.1%
	415922	10 Ω ± 0.1%
Shunt resistor for clamed terminal	438920	250 Ω ± 0.1%
	438921	100 Ω ± 0.1%
	438922	10 Ω ± 0.1%
Zip disk	A1056MP	250 MB
Card adapter (not including CF card)	772090	—
CF card (not including adapter)	772091	128 MB
	772092	256 MB
	772093	512 MB
	772094	1 GB
Fuse	A1347EF(DX100P)	250 V, 1 ATL
	A1352EF(DX100P/P1)	250 V, 4 ATL
Mounting bracket	B9900BX	—
Input terminal	438227	For /KB1, /KB2 option

EXTERNAL DIMENSIONS

Dimensions

Unit: mm
(approx. inch)

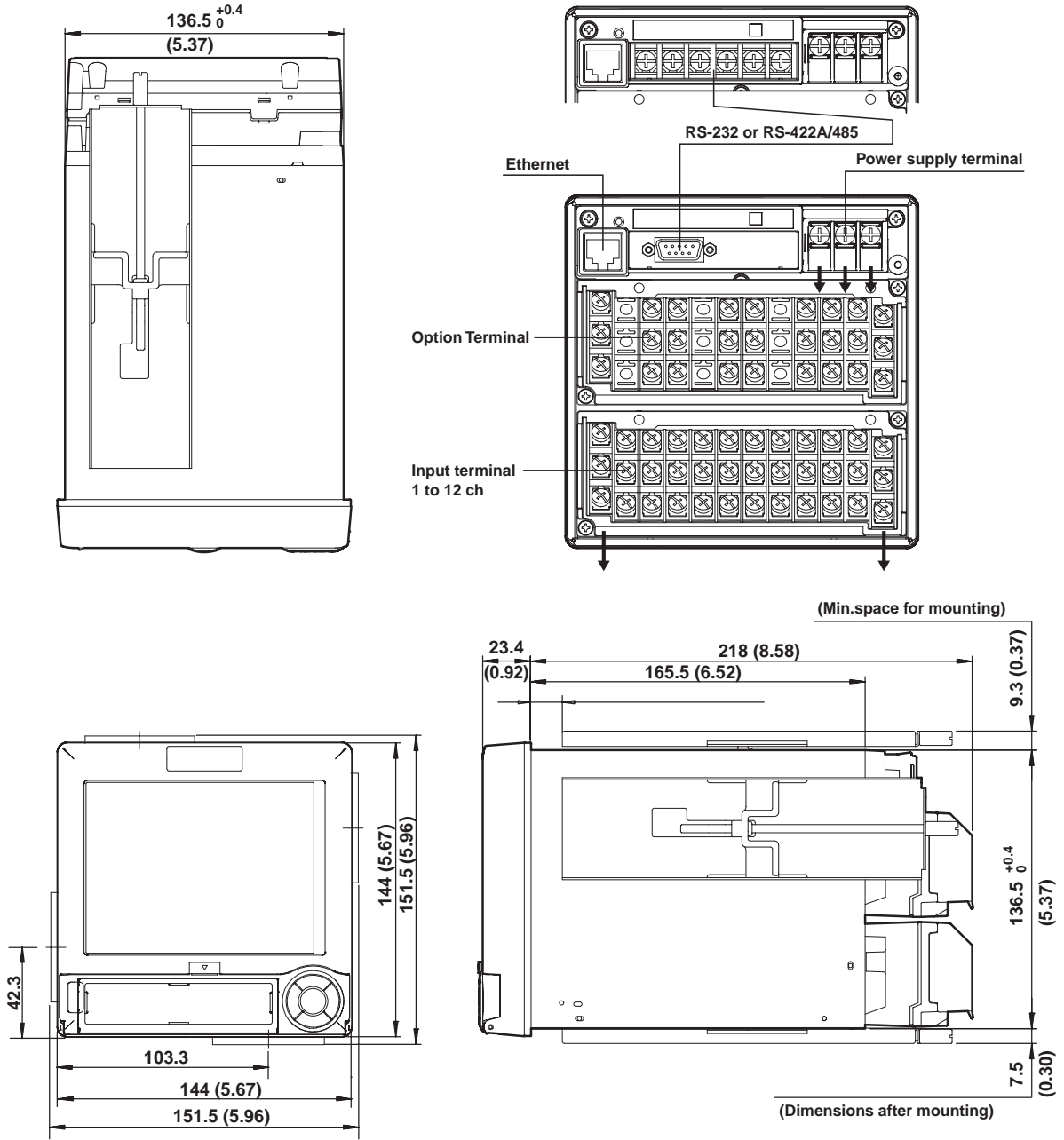

The tolerances are $\pm 3\%$ (± 0.3 mm for dimension less than 10 mm) unless otherwise specified.

Panel cutouts

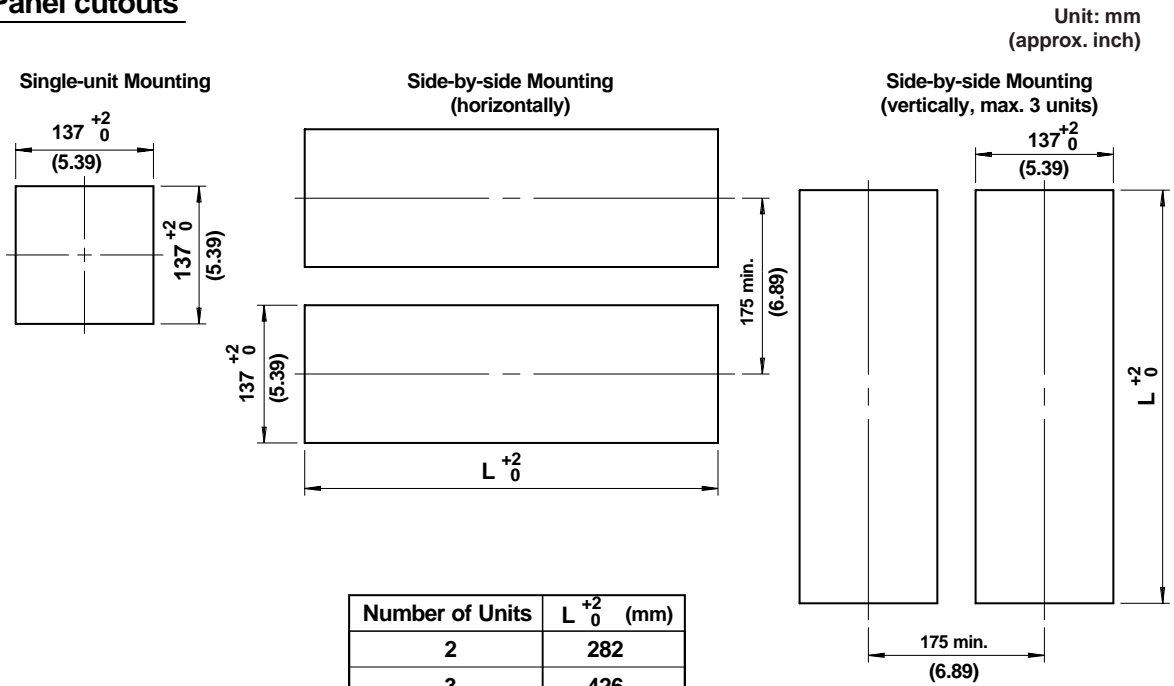

Number of Units	L ⁺² ₀ (mm)
2	282
3	426
4	570
5	714
6	858
7	1002
8	1146
9	1290
10	1434
n	(144 n) 6

The tolerances are ±3% (±0.3 mm for dimension less than 10 mm) unless otherwise specified.

Desk top type

Unit: mm
(approx. inch)

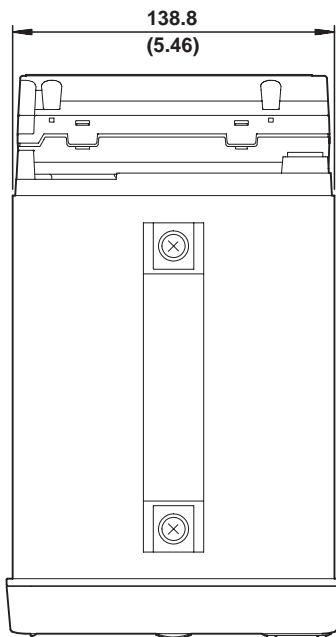

Rear view

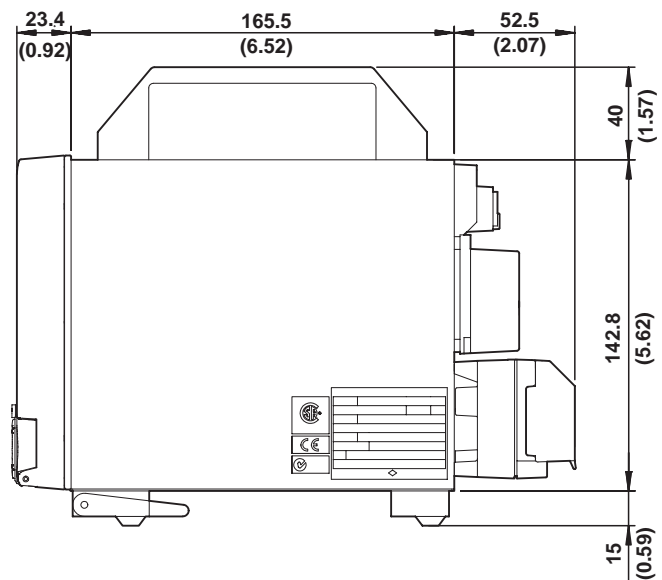
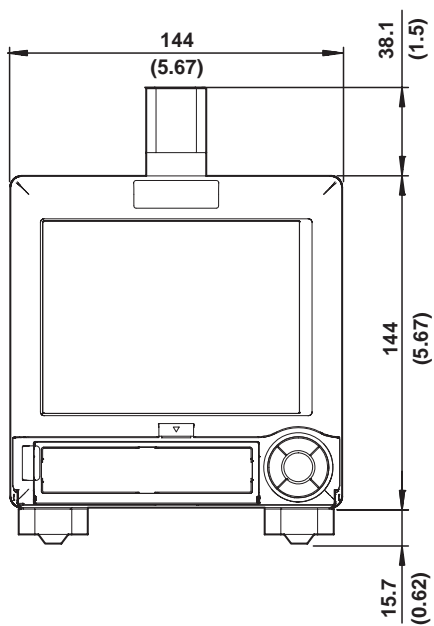
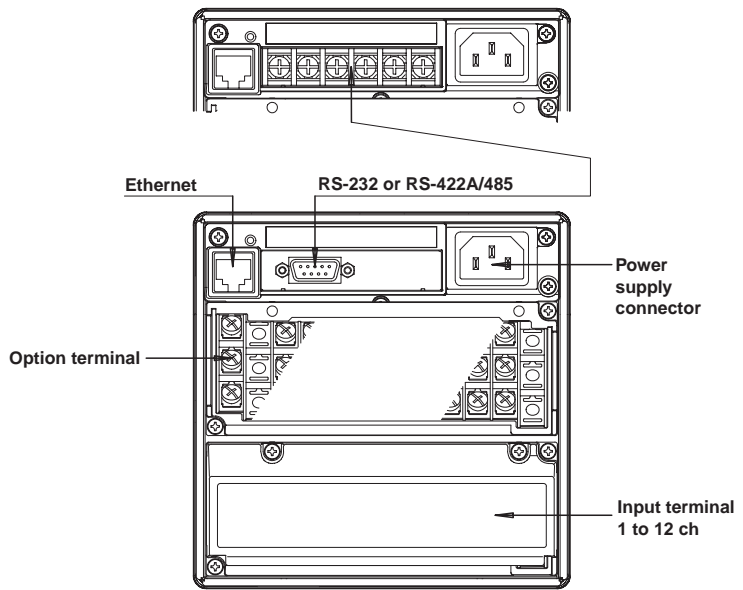

The tolerances are $\pm 3\%$ (± 0.3 mm for dimension less than 10 mm) unless otherwise specified.

Power supply terminal

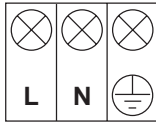

RS-422A/485 terminals

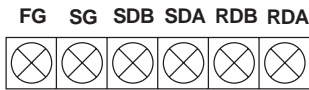

RS-232 terminal

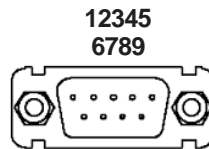

1	N.C.
2	RxD
3	TxD
4	DTR
5	GND
6	DSR
7	RTS
8	CTS
9	N.C.

Input terminals

Screw type for DX102P and DX104P

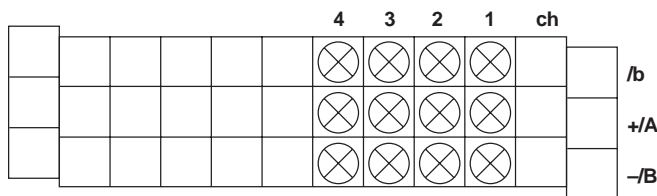

Clamp type for DX102P, DX104P, and DX106P (/H2)

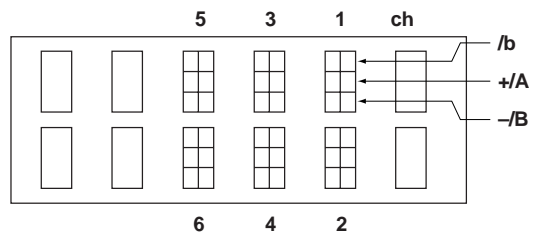

Screw type for DX106P

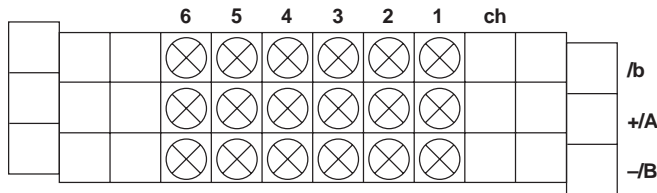

Clamp type for DX112P (/H2)

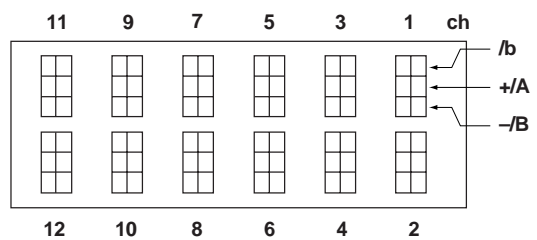

Screw type for DX112P

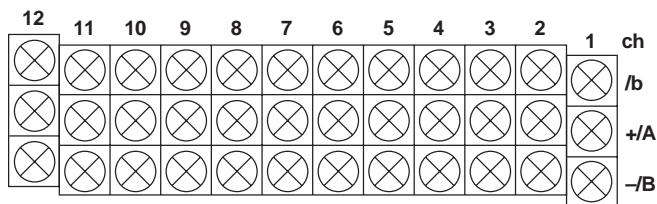

Option terminals

For /A3 /R1 Combination

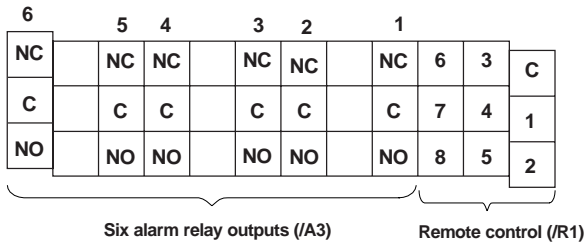

For /A2 /F1 /R1 Combination

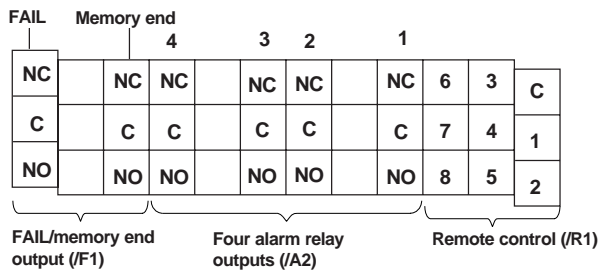

For /A1 /R1 /TPS2, /AR1 /TPS2 Combination

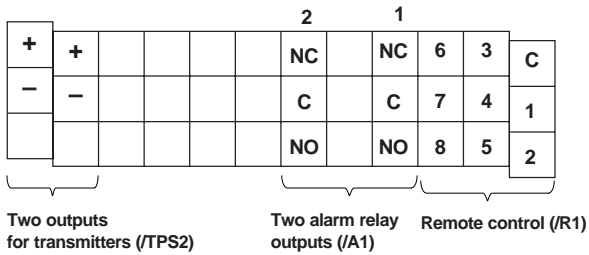

For /A1 /TPS2 Combination

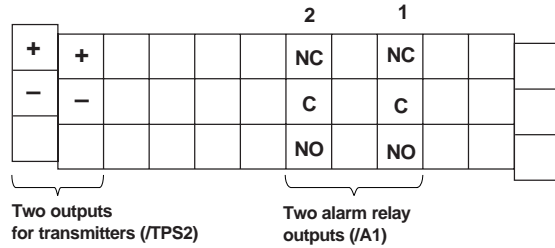

For /R1 /TPS2 Combination

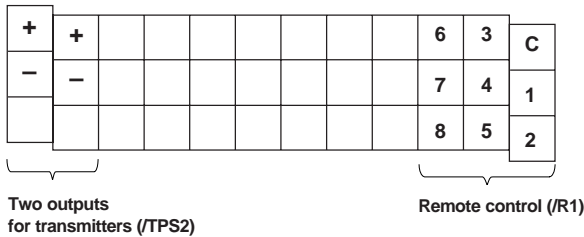

For /TPS2 Combination

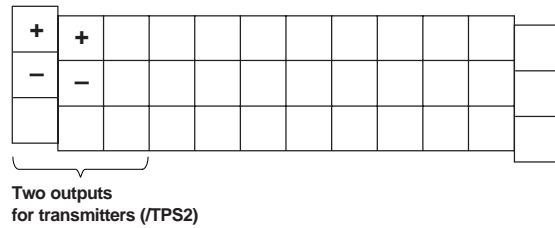

For /R1 /TPS4 Combination

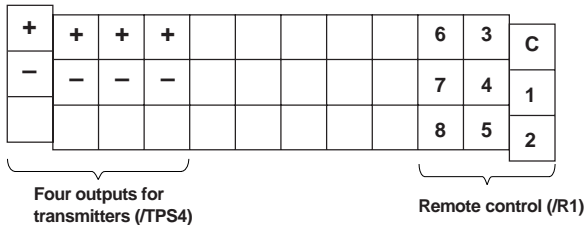

For /TPS4 Combination

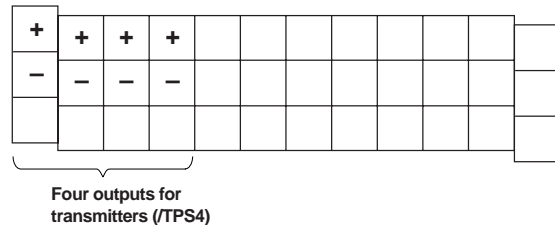

The TCP/IP software and related document for this product are developed and prepared by Yokogawa Electric Corporation based on BSD Networking Software, Release 1 under license from the University of California.

- DAQSTATION is a registered trademark of Yokogawa Electric Corporation.
- Microsoft, MS, and Windows are registered trademarks of Microsoft Corporation, the United States.
- Lotus and 1-2-3 are registered trademarks of Lotus Development Corporation.
- MMX and Pentium are registered trademarks of Intel Corporation, the United States.
- Ethernet is a registered trademark of Xerox Corporation.
- Modbus is a registered trademark of AEG Schneider Automation Inc.
- Zip is a registered trademark or trademark of Iomega Corporation, the United States.
- Other company and product names in this document are trademarks or registered trademarks of their respective holders.